

REVISIONS		
REV. NO.	DESCRIPTION	DATE

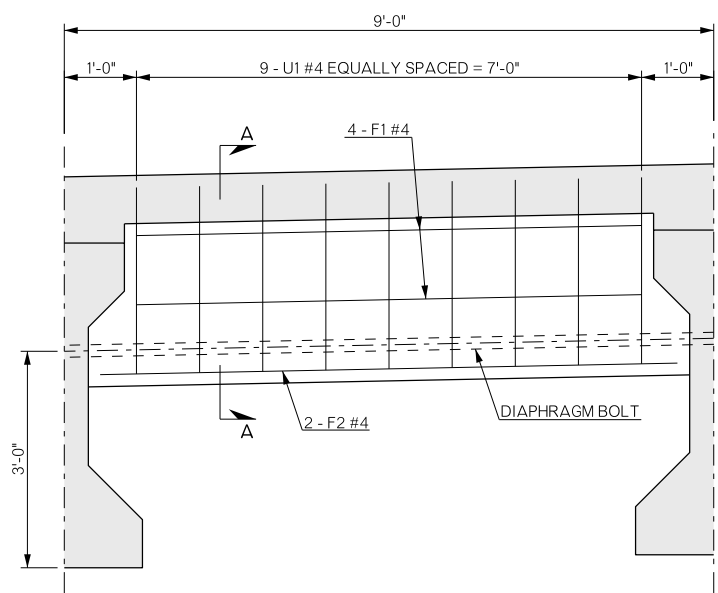

END DIAPHRAGM  
TYPE IV P.C. BEAM

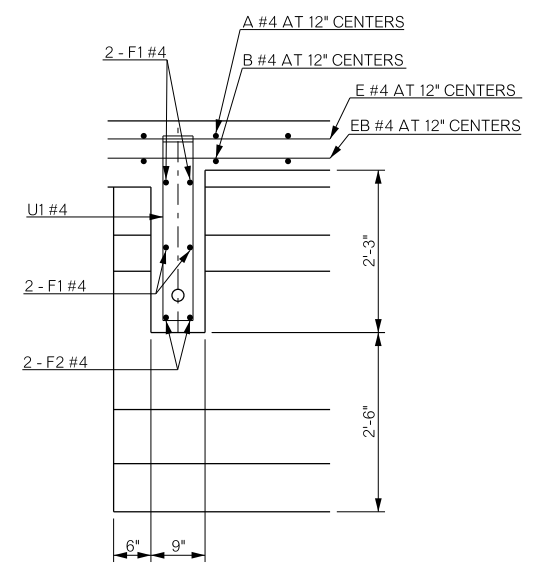

SECTION A-A

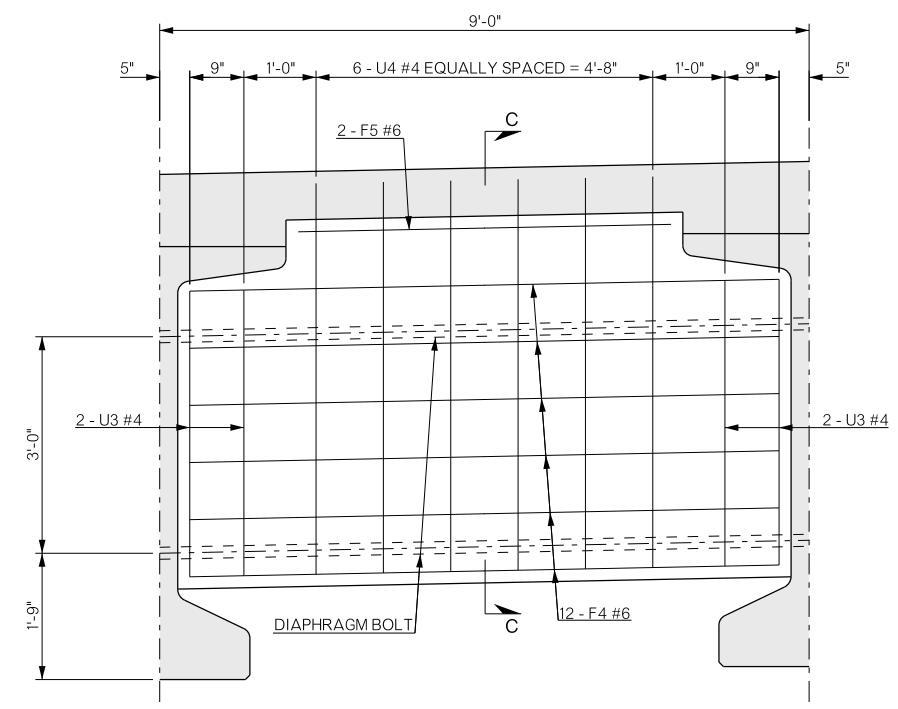

END DIAPHRAGM  
TYPE J P.C. BEAM

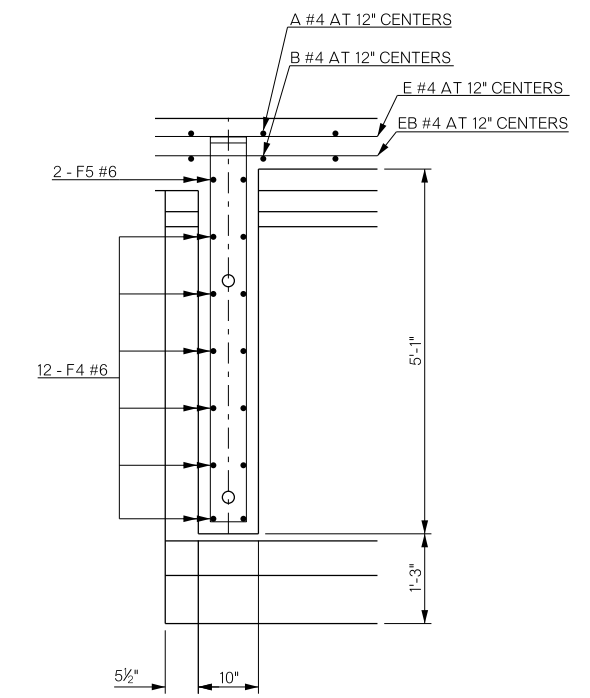

SECTION C-C

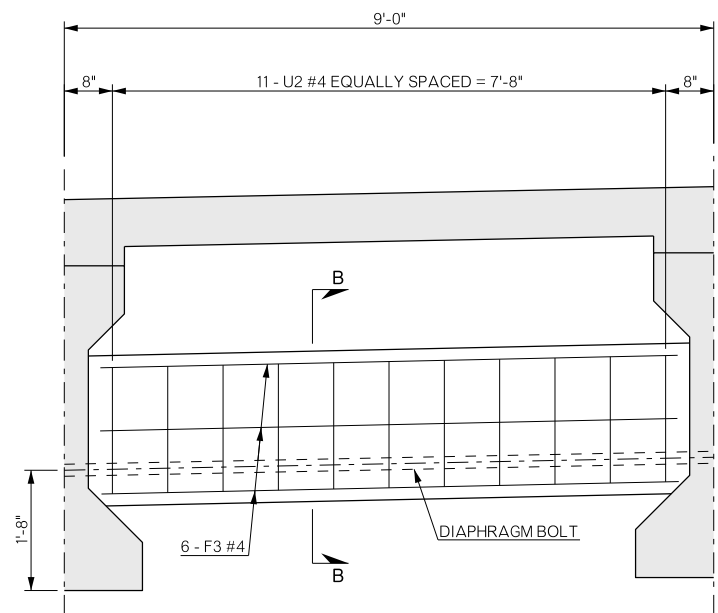

INTERMEDIATE DIAPHRAGM  
TYPE IV P.C. BEAM

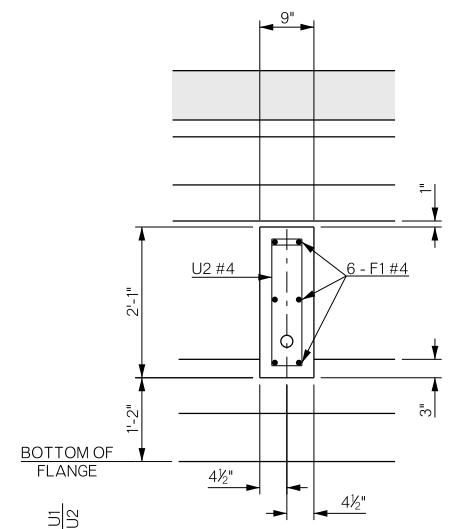

SECTION B-B

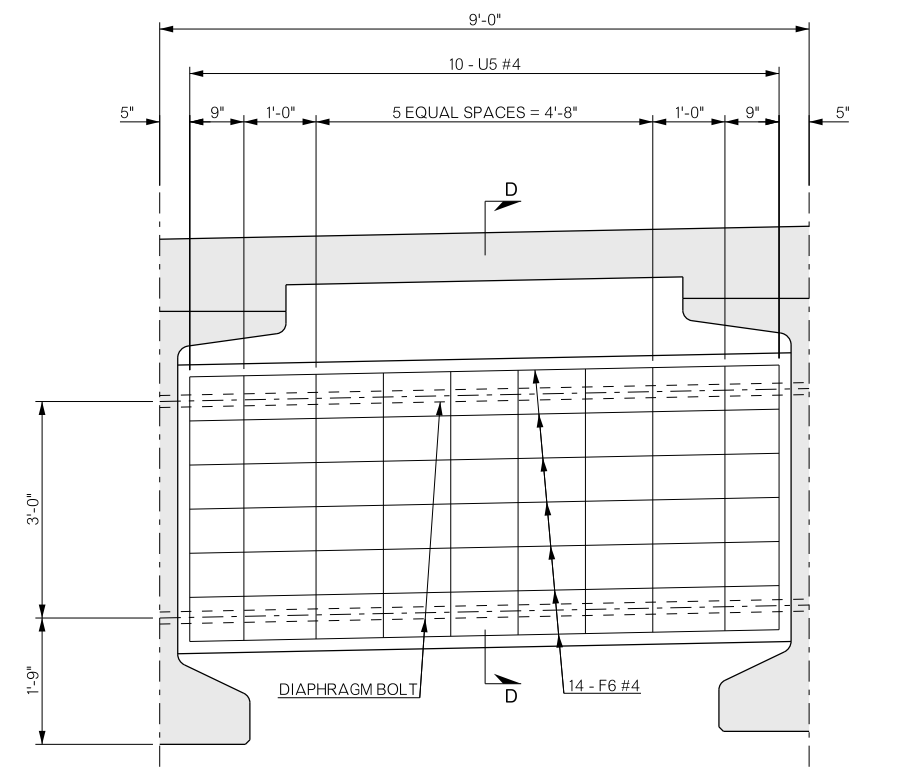

INTERMEDIATE DIAPHRAGM  
TYPE J P.C. BEAM

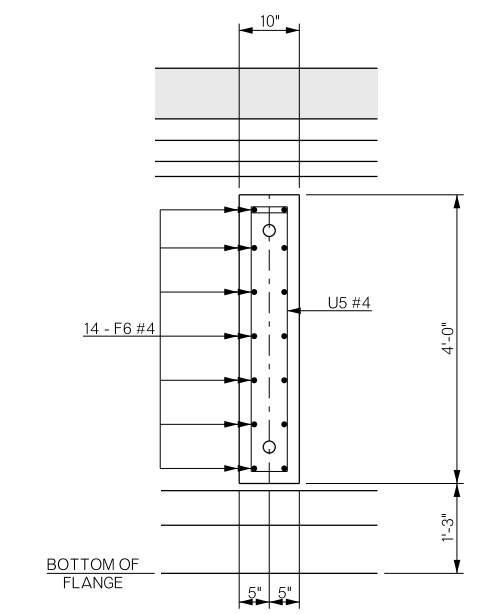

SECTION D-D

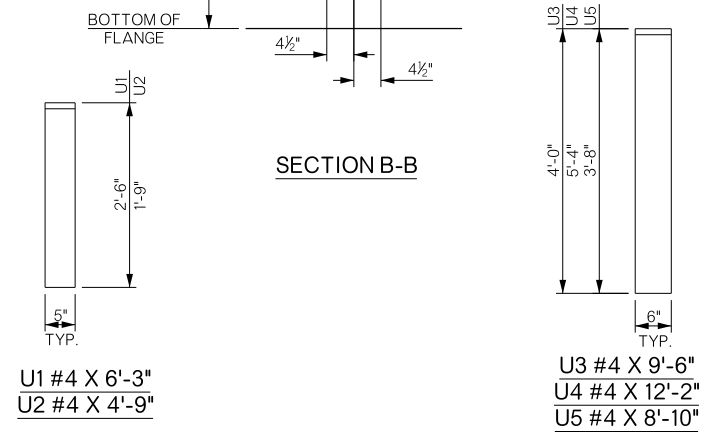

BRIDGE "A" SH-33 OVER COTTONWOOD CREEK	LOGAN COUNTY	Design	GT	11/15	
DETAILS OF SUPERSTRUCTURE (SHEET 14 OF 14)		Detail	TIS	4/16	
		Check			
		Squad	PEARSON		
		Engr.	HERNANDEZ		
STATE OF OKLAHOMA	DEPARTMENT OF TRANSPORTATION	JOB/PROJECT NO.	21860(04)	SHEET NO.	B067